

# Operation and Maintenance Manual

Dew Point Monitor

DP1011-50  
DP1011-60  
DP1011-80



  
**3DPROTOTECH**

# Introduction

For technical assistance, service or replacement parts, please contact:

**3DPROTOTECH**

5-110 Riviera Dr.  
Markham, ON  
L3R 5M1 Canada

876 Jamaica Ave.  
Brooklyn, NY  
11208 USA

Tel: 905 235 7811

Email: [sales@3dproto.ca](mailto:sales@3dproto.ca)

# Table of Contents

Introduction .....	2
Table of Contents.....	3
Safety Precautions .....	4
General Information .....	4
Product Description .....	4
Installation.....	5
Gas Connection.....	5
Power Connection .....	5
Sensor Connection.....	5
Remote Monitoring Connection .....	5
Remote Analogue Signal (Optional if equipped) .....	6
Operation .....	6
Sequencing of operation.....	6
Main Screen .....	6
Dryer Status, Purging & Economy Mode Setup .....	6
Dew Point Alarm Setup .....	7
Faults and Alarms .....	7
Dew Point Failure .....	7
Dew Point High Alarm .....	7
Maintenance .....	7
Dew Point Sensor Calibration.....	7
Warranty .....	8
Technical Support .....	8

## Safety Precautions

Operator should have carefully read and become familiar with the operation of this unit prior to installing, wiring, starting, operating and maintaining the equipment. It is expected that the operator uses standard safety precaution and good workmanship practice while working on the unit.

Unit should be operated based on local regulation applicable to where the unit are being installed and operated.

Pressurized air in the air line can cause damage to property and personnel injury. Ensure pressure is released from the line prior to removal of any pressurized parts.

## General Information

### Product Description

Dew Point Monitor will have a Human Machine Interface (HMI) screen that will allow for variable adjustments, visual indication of the system status and alarms. The DP1101 will be able to monitor Dew Point (DP). The controllers will have an alarm silence/ reset button. Controllers are assembled in a NEMA type 12 enclosure, factory wired, tested for quality assurance and UL508A compliance.

Suggested operating temperature: 78°F (26°C).

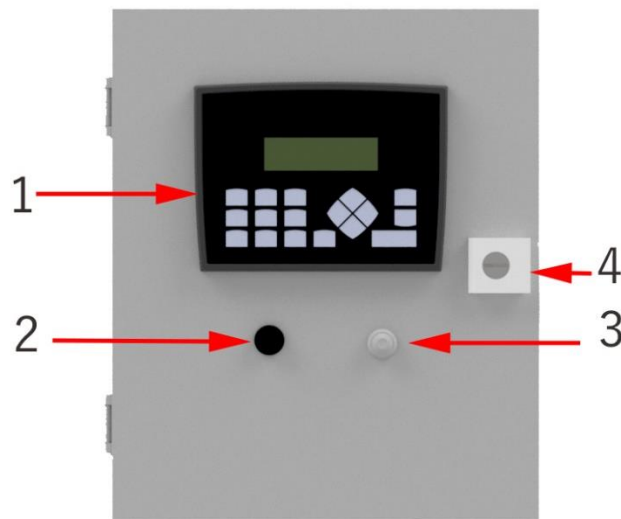

1. Human Machine Interface (HMI)
2. Buzzer
3. Illuminated silence/reset button
4. Enclosure lock

# Installation

## Gas Connection

The dew point sensor is a ½ NPT gas connection. To sample the gas, here are the methods that are available.

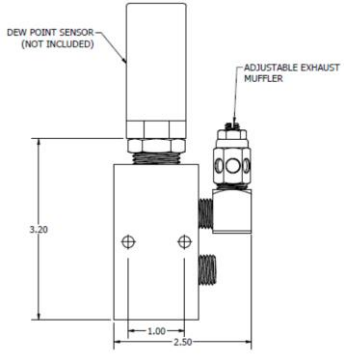
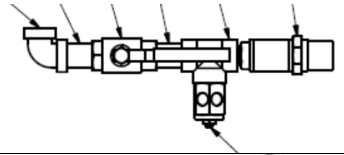
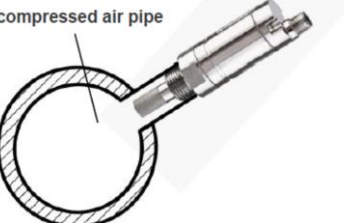
	<p><b>Sample gas assembly (Recommended)</b> Mount the assembly either on the panel (Factory will factory mount this assembly when ordered together) or at a remote location. Connect the sensor to the top of the block and connect the sample gas to the bottom of the block.</p>
	<p><b>Sample gas piping</b> Screw in probe with ½ NPT thread pressure-tight at the end of the tube. Install a bleed valve prior to the gas sensor to allow for an adjusted flow across the sensor element.</p>
	<p><b>Directly in the compressed air system</b> Screw in probe with ½ NPT thread pressure-tight in the center or at the top of the compressed air pipe. Take care that measurement is effected close to the compressed air flow. U-bend pipes or non-flowing compressed air, result in very slow reaction times for the moisture reading.</p>

## Power Connection

DP1101 is supplied with a standard North America 110VAC power cord for power connection. You may wish to replace it with a hard wire connection if needed by removing the power cord and connecting the on-site connection to the “L” “N” and “G” terminal

**Warning:** This must be done by electrician in accordance to local regulation

## Sensor Connection

The dew point sensor connection cord is provided. Connect the Red wire to terminal “101 and the Black Wire to “102” for sensor connectivity.

The dew point sensor has a connector provided inside the sensor box. Connect the Red Wire in to the connector pin 3 and the Black Wire to connector pin 1.

## Remote Monitoring Connection

DP1101 is provided with 2 alarm dry contact relays.

AR1 – Dew Point High Alarm – Connect to remote alarm monitor system

R1 – Dryer Economy Mode – Connect to desiccant dryer

Each relay is provided with terminal 11 as common, 12 as normal closed and 14 as normal open.

### Remote Analogue Signal (Optional if equipped)

Models with AO indicates the availability of analogue signal for remote monitoring of dew point. Terminals will be provided for connection. From remote location, supply negative to the 0V terminal and connect the signal to terminal 118

## Operation

### Sequencing of operation

Operations of the controllers are based on dew point. A dry contact signal will be sent to the desiccant dryer controller to begin purging when dew point levels go above the purge set-point, and, will stop when the dew point levels drop below the economy set-point. If a high dew point is detected controller will signal a high dew point alarm.

### Main Screen



DP: 104.0F PURGE

- The current Dew Point (DP) level is displayed in degrees Fahrenheit (F).
- In case sensor fails the DP will display “104.0F” and “FLT!” will alternate with “DP” on display
- After sensor is repaired, controller should resume monitoring the DP, to clear sensor fault push alarm silence/reset button for 3 seconds to reset. (See paragraph “Faults & Alarms” for additional information)

### Dryer Status, Purging & Economy Mode Setup

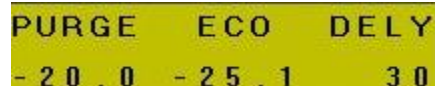

PURGE	ECO	DELY
-20.0	-25.1	30

DP1101 will display notification that system is in Purge or Eco mode.

We can adjust the Purge and Eco set points on both controllers. (See Purging and Economy Mode to setup these set-point).

Purge mode becomes active when the DP level reaches above the purge set-point and allows the dryer to purge. Economy mode becomes active when the DP level reaches below the economy (ECO) set-point and stop the dryer from purging.

- This screen can be access by pressing the right directional arrow from the Main Screen.
- Press Access/Enter button to enter into edit mode.
- Enter the desired Numeric value
- Use the Access/Enter to jump between fields or the left and right arrow directional buttons.
- “i” button to return to main screen.

## Dew Point Alarm Setup

DP ALARM: 35.0

Use the left and right directional arrows to locate the Alarm Set Points screen. On this screen you can adjust the High Set Point of the DP Alarm and the CO Alarm.

- Press Access/Enter button to enter into edit mode.
- Enter the desired Numeric value
- Use the Access/Enter to jump between fields or the left and right arrow directional buttons.
- “i” button to return to main screen.

## Faults and Alarms

When there is no alarm, the illuminated button will be lit green to indicate there are no alarm condition. When there is an alarm condition, the buzzer will sound and the illuminated button will be lit red. To silence the alarm without reset, touch and release the illuminated button. To reset, touch and hold the illuminated button for 3 seconds. If the alarm condition still exists, the buzzer will sound again and the illuminated button will be lit red as well.

### Dew Point Failure

Dew Point Transducer fail alarm is available on DP1101. This alarm is a latching alarm with audio and visual indication. A dry contact is provided for remote monitoring of this alarm. This occurs when a dew point sensor is connected incorrectly or has stopped working. The main screen will show a message “FLT!” instead of a dew point read out. There is also a time delay of 30 seconds preprogram so the alarm will only trigger after this time has elapsed. Check the condition of the sensor and wiring if this alarm occurs.

### Dew Point High Alarm

Dew point high alarm is available on DP1101. This alarm is a latching alarm with audio and visual indication. A dry contact is provided for remote monitoring of this alarm. This occurs when a dew point is above the dew point alarm set point. The main screen will show a message “HI!” instead of a dew point read out. There is also a time delay of 30 seconds preprogram so the alarm will only trigger after this time has elapsed.

## Maintenance

### Dew Point Sensor Calibration

3D Prototech Corp. recommends the dew point sensor be replaced or calibrated annually due to sensor drift over time. For calibration, please contact 3D Prototech Corp.

## Warranty

3D Prototech Corp. warrants the equipment to be free of defects in materials or workmanship when installed and operated in accordance with instructions. The Warranty Period will be (12) months commence upon shipment of the product. This warranty covers the replacement of defective parts and shipping costs within the continental United State and Canada.

This warranty covers all necessary parts as defined in the Conditions of Standard Warranty Periods, required for correction of the defect whether by any or all of replacement, or credit, which election shall be made by 3D Prototech Corp. at its sole discretion, and which are purchaser's only remedies for breach of warranty.

This warranty requires the owner to ensure that the equipment is:

- Installed in accordance with installation and maintenance manuals provided with the product
- Certified in accordance with all applicable local standards, by a properly qualified certification agency
- Maintained in strict accordance with Operation and Maintenance Instructions provided with the product

Warranty claims will be honored only after defective parts are evaluated by 3D Prototech Corp and only when the examination discloses to 3D Prototech Corp's reasonable satisfaction that the equipment has not been damaged in shipment or improperly installed, operated outside of any published parameters (including but not limited to mechanical, electrical, temperature, pressure, or ventilation), improperly or inadequately maintained, field modified in any way, improperly repaired, or in any other way improperly applied or used.

All claims against this warranty require prompt notification, within the warranty period, of any seeming defect. Failure to promptly notify 3D Prototech Corp. of the seeming defect will invalidate all warranties.

3D Prototech Corp. is not liable for delay, damage or defect caused by shipping, acts of God, fire, war, labor difficulties, action of government, or other cause beyond the reasonable control of 3D Prototech Corp. If there is a material delay in delivery for any reason, purchaser's only remedy is to cancel the purchase order.

This warranty is given in lieu of all other warranties, expressed or implied, including implied warranties of fitness for a particular purpose and merchantability. In no event is 3D Prototech Corp. liable for damages in excess of the value of the defective product, nor is 3D Prototech Corp liable for any indirect, special or consequential damages, loss of profit of any kind, or for loss of use of the products, even if 3D Prototech Corp. is aware or should be aware of the possibility of the same.

## Technical Support

For further information regarding this product, please contact 3D Prototech Corp. or visit [www.3dproto.ca](http://www.3dproto.ca)